

# Human Brain Image Database System (HBIDS) for Epilepsy

## Participants:

1. Hamid Soltanian-Zadeh, PhD, Principal Investigator
2. Mohammad-Reza Siadat, MS, PhD Candidate, Co-Investigator
3. Farshad Fotouhi, PhD, Co-Investigator
4. Kost V. Elisevich, MD, PhD, Co-Investigator
5. Sonali Karandikar, BS, Software Specialist

## 1. Introduction, motivation, and goal

Quantitative assessment by imaging modalities of a human condition is typically encumbered by large pool of data. The human central nervous system lends itself to detailed study of its structural and functional aspects by several modalities. The outcome of such study is crucial in determining operability in situations such as epilepsy. Two primary issues are motivating us in this work that underline difficulties in current approaches to such analysis:

1. Image data cannot be fully described textually. For instance, there is no means by which one can easily and uniquely describe a textural pattern by number or a set of characters, that is, the visual information is unstructured. A text-based query language (e.g., SQL) for retrieval purposes is therefore unsuitable.
2. Most of the content-based image retrieval (CBIR) methods take the overall appearance or the global features of the images into account [1]-[5]. In a few proposed CBIR methods using the local features [6]-[8], the focusing areas (the segmented regions, detected edges, etc.), are not associated with high-level objects, that means they are semantically poor. Therefore feature extractors and retrieval methods addressed in current CBIR literature cannot be used to distinguish brain images with subtle anatomical differences.

The goal of this project is to develop a human brain image database system (HBIDS) for epilepsy. To remedy the above limitation of the CBIR methods, we have included a new, semantically strong knowledge-based segmentation module [9]-[11] into the proposed HBIDS. The brain segmentation poses a challenge as brain structures typically have multiple edges or missing boundaries in some parts. Confining our content-based visual extractor routines upon segmented structures, we map the low-level image features to the semantics associated with the high-level objects defined within the data model. We can then query the unstructured image data by their contents. Therefore the proposed HBIDS will examine surgical candidacy among temporal lobe epilepsy patients based on their brain image and other data modalities. Moreover, it can discover relatively weak correlations between, symptoms, medical history, treatment planning, outcomes of the epilepsy surgery and brain image data.

The data include modalities such as MRI (T1, T2, FLAIR) and SPECT (ictal, interictal) along with patient's personal/medical information and EEG study.

## 2. Methods

The novelty of the proposed method is mainly due to the new segmentation method and the way it is integrated into the HBIDS. Since hippocampus is an extremely important brain structure, e.g., for epilepsy diagnosis and treatment, the focus of the segmentation method is on this structure. Hippocampus is a relatively small structure of the human brain limbic system. Visual and architectural features of this structure have been studied for epilepsy and Alzheimer's diseases [12]-[14]. Hippocampus is characterized by multiple edges and missing boundaries in some parts in the MRI scans. As a result, segmentation of this structure is very challenging. We are planning to segment other structures of the brain, which are of interest for epilepsy (e.g., parahippocampal gyrus) as the project progresses. In the following, first the segmentation module and then the HBIDS architecture are described.

## 2.1. Brain Structure Segmentation

The proposed segmentation method has two steps and is fully automatic. The first step is brain structure localization and the second step utilizes a 3D deformable model for an accurate and high-resolution segmentation.

### 2.1.1. Brain Structure Localization

The localization procedure finds several landmarks around the desired structure. We create binary images representing gray matter (GM) and cerebrospinal fluid (CSF). The proposed method finds certain landmarks from specified points of view and within specified fields of search, using the binary images. Morphological routines are utilized to extract the connected components/segments to the landmarks. A rule-based system with a set of 35 rules is used to analyze the extracted landmarks and segments. This rule-base system assigns each individual landmark an intermediate confidence factor (ICNF). The ICNF shows how accurately each individual landmark/segment is found. An approximate reasoning procedure calculates an overall confidence factor (CNF) from the ICNFs. Setting a threshold for overall CNF, we determine if hippocampus exists in the slice and how accurate its landmarks are (See [9], [10] for further details). Fig. 1(b), (c) shows the results of hippocampus localization on the coronal and sagittal views of a set of T1 weighted MRI scans.

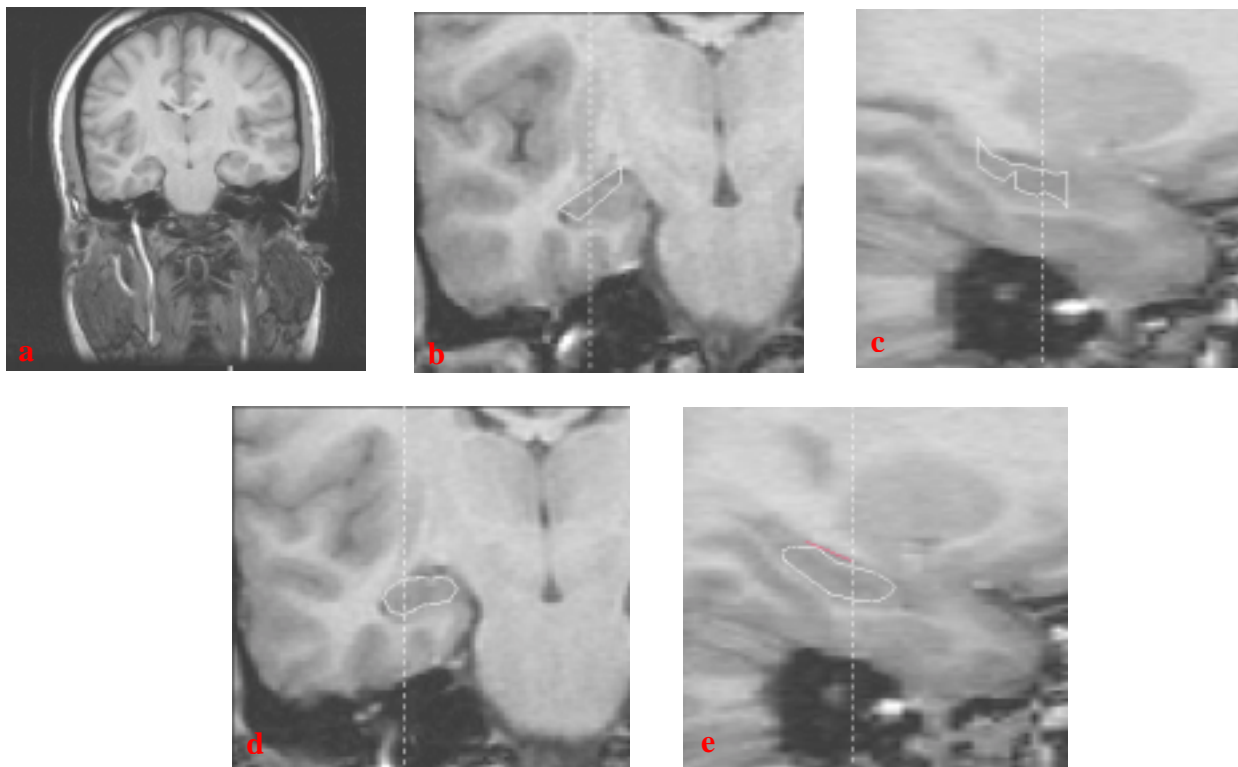

Fig. 1. a) a coronal view of the human brain T1 weighted MRI with hippocampus, b, c) The hippocampus localization results on coronal and sagittal views, using the knowledge-based localization method, d, e) the segmentation results on coronal and sagittal views, respectively, using the 3D deformable model.

### 2.1.2. 3D Deformable Model

The proposed 3D deformable model converts the localization results (as an initial polygon) to an accurate and high-resolution 3D model of the structure. The task is done by adding more vertices to the initial model and moving them based on the internal and external forces iteratively until the termination condition is met. The internal forces are calculated from local model curvature, using a least-squares error approximation. The external forces are calculated

by applying a step expansion and restoration filter (SEF) to the image data. A solution for self-cutting problem has been proposed via principal axis analysis and re-slicing (See [11] for further details). Two orthogonal views (coronal and sagittal) of the final result are illustrated in Fig. 1(d), (e).

## 2.2. HBIDS Architecture

Considering the data model, the proposed HBIDS is a relational database. Here we focus our attention on the architecture of the HBIDS graphed in Figs. 2, 3 and 4.

### 2.2.1. Segmentation Module

The “Segmentation Module” generates a 3D model for the desired brain structure from the specified image modality (usually T1-weighted scans) based on the method proposed in 2.1. This module includes: 1) “Localization parameters estimator” which is a histogram analysis program to determine the threshold values for generating binary images, 2) “Deformable model parameters setting” which is a set of fixed parameters for each particular brain structure determined by the segmentation designer, 3) “Knowledge-based localization” and, 4) “3D deformable model” as explained in 2.1.1 and 2.1.2, respectively. Fig 2 highlights the segmentation module and shows its interaction with the other parts of the HBIDS.

The 3D segmented model is stored in a text file using the VTK (Visualization Tool Kit) format, so that VTK software can be employed to visualize the model as a graphical object. Further, it can be used to augment the 2D brain images with an appropriate graphical 3D view of the model. Physically, the model is stored in the database along with the parameters used to build the model.

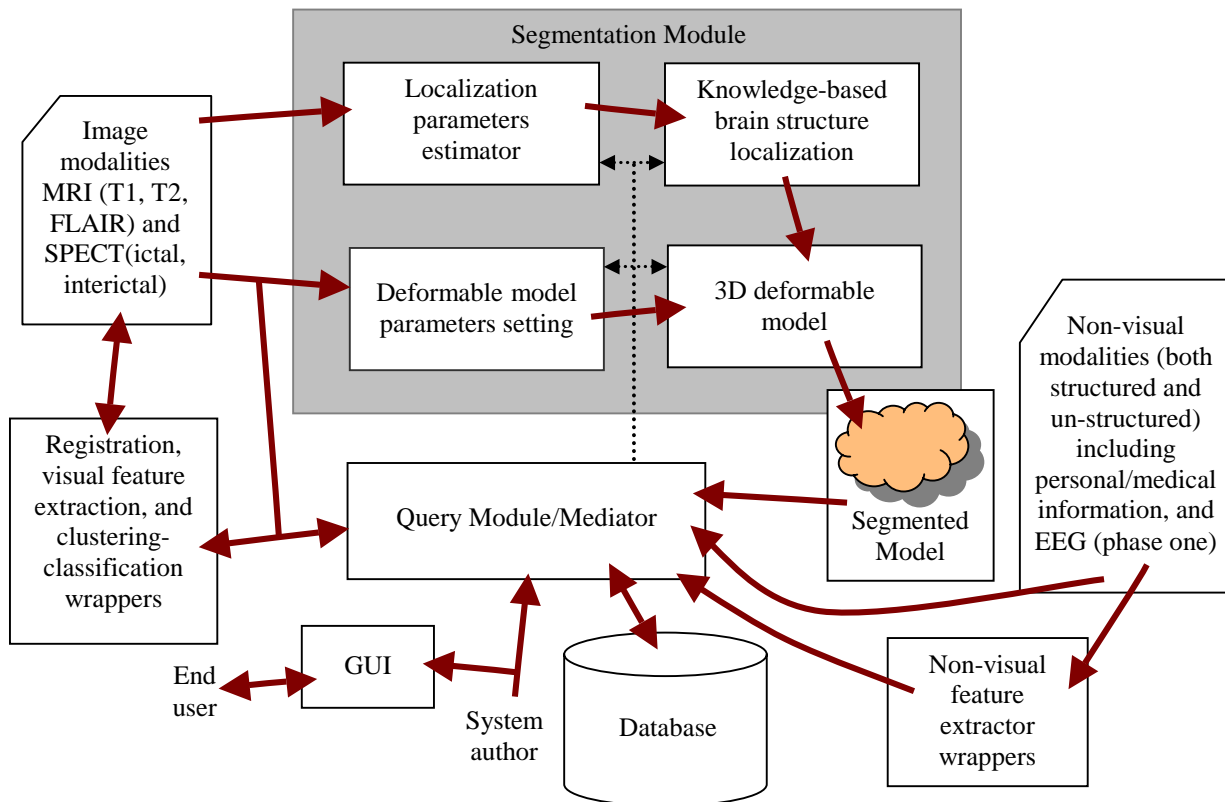

Fig. 2. The HBIDS architecture: the segmentation module is highlighted.

### 2.2.2. Registration Module

The segmented model is determined using a single modality (usually T1). But it is used to calculate the visual features of the desired structure over the other modalities as well. Therefore we need an application to align other modalities with the one used for segmentation. Doing so pixels with the same coordinates from different modalities point to the same position in the image space. The “registration module” does the above procedure. Fig 3 highlights the registration module and shows its interaction with the other parts of the HBIDS.

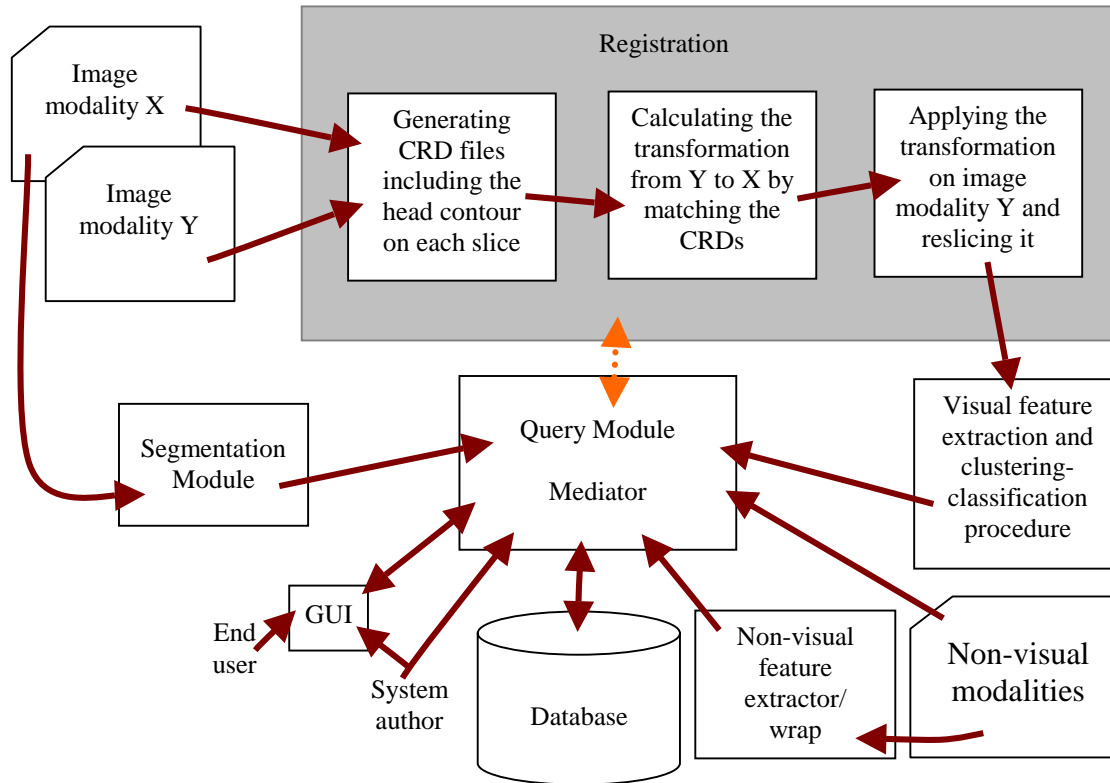

Fig. 3. The HBIDS architecture: The registration module is highlighted.

### 2.2.3. Visual Feature Extraction and Clustering-Classification Modules

The visual feature extraction module includes a set of applications (wrappers) each of which calculates the visual features (color, texture and shape) within the segmented model and on the proper image modality. There are a variety of features such as volume, surface area, intensity mean-value and standard deviation, length, width, and principal vectors that are of interest. These features are calculated once the segmented model is built. The information is stored along with the segmented model in the database (off-line procedure). Furthermore, there are features we may find of interest later, or we do not have its wrapper yet. In such cases, we can simply add the new feature extractor when it is available as a new application to the visual feature extraction set. Using the extracted features, the clustering/classification module decides if the image set is going to be of interest (on-line procedure) and then the query module decides which part of the associated data should be retrieved. Fig 4 highlights the visual feature extractor module and shows its interaction with the other parts of the HBIDS.

### 2.2.4. Query Module

The “Query Module” acts like a mediator in the sense that depending on the input query, it decides about the job scheduling and the flow of the information. It decides from which image modality the required information should

be retrieved. The query module activates the histogram analysis and plugs the estimated threshold values into the localization sub-module. Similarly, it retrieves an appropriate set of parameters for 3D deformable model and activates it. The results of any application run on the data are stored in the database by the query module. The decision about which visual feature extractor or registration wrapper should be used is also up to the query module. In case the segmentation is already done, the query module may retrieve the model from the database for further analysis. All these actions are taken by the query module based on the input query issued by the user.

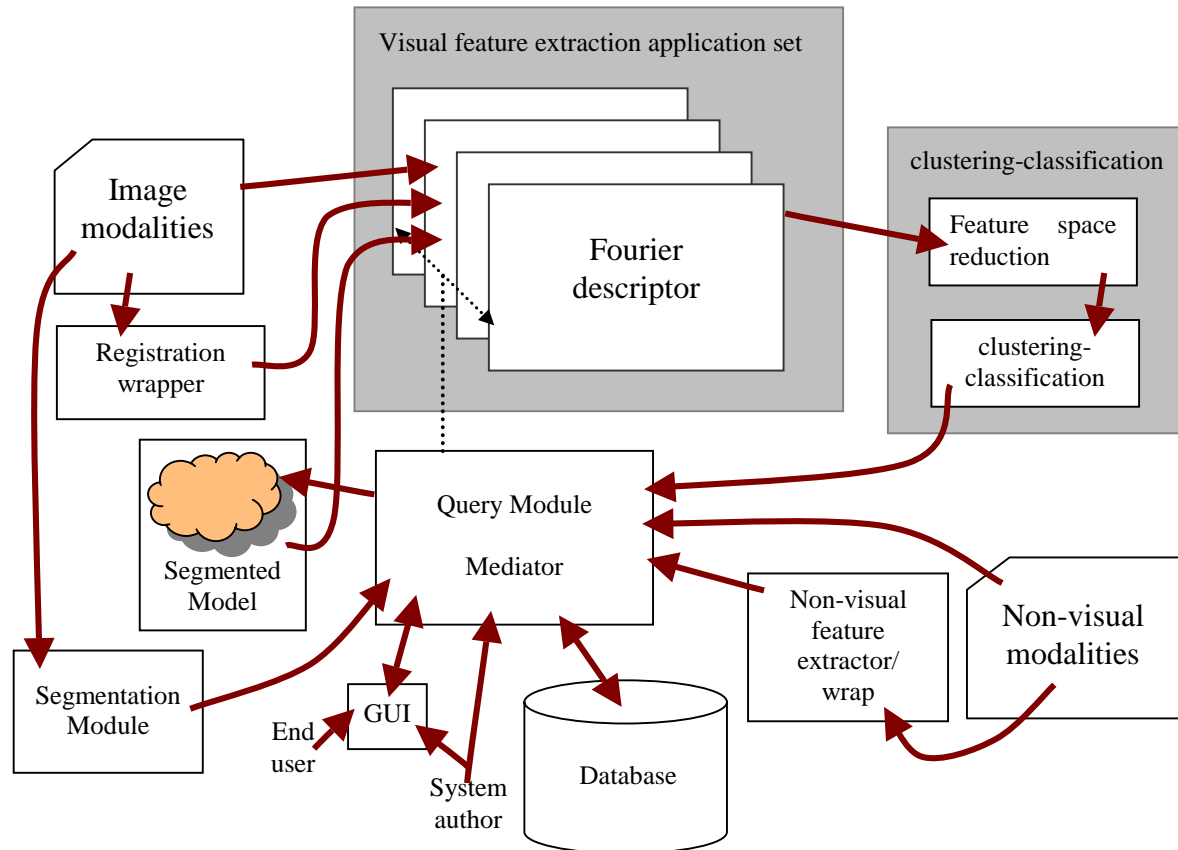

Fig. 4. The HBIDS architecture: The visual feature extractor module is highlighted.

### 2.2.5. Non-Visual Feature Extractors

For the phase one of the EEG study, the non-visual feature extractor (wrapper) can be either a 1D signal processing algorithm or an expert/specialist. We have the experts do this work since it is a routine in the clinics, done based on well-defined standards. For unstructured text information, the wrapper is either an expert/trained nurse (data analyst) or natural language analyzer software. We have an expert extract the information. The structured data such as patient's personal information do not need to be analyzed by the wrapper, so they are directly stored in the database. System author is either an individual surgeon/radiologist or a group of them. The end user could be a surgeon or group of them and/or their students. The HBIDS is currently under development. The database management system (DBMS) is oracle software and front-end is web-based using java servlet pages.

## 3. Preliminary Results and Conclusions

The proposed system renders efficient analysis of brain imaging data (i.e., MRI, SPECT) along with the other data modalities for individual and comparative group study. Although, the HBIDS is focused on epilepsy, the proposed method can be adopted for similar medical applications. As a result of adding segmentation to the database, the

semantics contents of the image data can be queried. The HBIDS can eventually answer queries such as: "What is the correlation between the attribute\_X of the entity\_Y and outcome\_Z?" where entity\_Y can be a brain structure (e.g., hippocampus) and attribute\_X can be any attribute of entity\_X (e.g., average intensity, volume) and outcome\_Z can be any result of an epilepsy surgery (e.g., memory quotient improvement). Queries like the above are crucial for surgery candidacy determination for epileptic patients. We have already segmented the hippocampus for 24 patients from T1-weighted MRI scans. The attributes of the hippocampus such as volume, surface area, intensity mean-value and standard deviation are calculated based on the segmented model. A query such as "What is the average of R\_V (minus) L\_V for patients with left-side operation before the surgery?" resulted in 275.7 mm<sup>3</sup>. Where L\_V and R\_V stands for the volumes of the left and right hippocampi.

#### 4. References

- [1] M. Flickner, H. Sawhney, W. Niblack, et al. "Query by Image and Video Content: The QBIC System," *IEEE Comput.*, pp. 23-32, Sept. 1995.
- [2] Y. Hara, K. Hirata, H. Takano, S. Kawasaki "Hypermedia Navigation and Content-Based Retrieval for Distributed Multimedia Databases," *Proc. of 6<sup>th</sup> NEC Research Symposium on Multimedia Computing*, 1995.
- [3] P.M. Kelly, T.M. Cannon, D.R. Hush, "Query by Image Example: The CANDID Approach," *SPIE*, vol. 2420, pp. 238-248, 1995.
- [4] A. Pentland, R.W. Picard, S. Sclaroff, "Photobook: Tools for Content-Based Manipulation of Image Databases," *Proc. SPIE Conf. on Storage and Retrieval for Image and Video Databases*, pp. 34-47, 1994.
- [5] H.S. Stone, C.S. Li, "Image Matching by Means of Intensity and Texture Matching in the Fourier Domain," *Proc. SPIE Conf. on Image and Video Databases*, pp. 337-349, 1996.
- [6] C.C. Hsu, W.W. Chu, R.K. Taira, "A Knowledge-Based Approach for Retrieval Images by Content," *IEEE Trans. On Knowledge and Data Eng.*, vol. 8, no. 4, pp. 522-532, 1996.
- [7] W.W. Chu, C.C. Hsu, et al., "Knowledge-Based Image Retrieval with Spatial and Temporal Construct," *IEEE Trans. On Knowledge and Data Eng.*, vol. 10, no. 6, pp. 872-888, 1998.
- [8] F. Korn, N. Sidiropoulos, et al., "Fast and Effective Retrieval of Medical Tumor Shapes," *IEEE Trans. On Knowledge and Data Eng.*, vol. 10, no. 6, pp. 889-904, 1998.
- [9] M. Siadat, H. Soltanian-Zadeh, "An Intelligent Approach for Locating Hippocampus in Human Brain MRI," *Proc. 16<sup>th</sup> IASTED AI'98 Conf.*, Feb. 1998.
- [10] H. Soltanian-Zadeh, M. Siadat, "Knowledge-Based Localization of Hippocampus in Human Brain MRI," *SPIE*, vol. 3661, pp. 1646-1655, 1999.
- [11] A. Ghanei, H. Soltanian-Zadeh, "A Knowledge-Based Deformable Surface Model," *SPIE*, vol. 4322, pp. 356-365, 2001.
- [12] C.R. Jack, C.K. Twomey, et al., "Anterior Temporal Lobes and Hippocampal Formations: Normative Volumetric Measurements from MR Images in Young Adults," *Radiology*, vol. 175, no. 2, pp. 423-429, 1990.
- [13] C.R. Jack, F.W. Sharbrough, et al., "Temporal Lobe Seizures: Lateralization with MR volume Measurements of the Hippocampal Formation," *Radiology*, vol. 175, no. 2, pp. 423-429, 1990.
- [14] C.R. Jack, R.C. Petersen, P.C. O'Brien, et al., "MR-Based Hippocampal Volumetry in the Diagnosis of Alzheimer's Disease," *Neurology*, vol. 42, no. 1, pp. 183-188, 1992.