

CLUSTERING-BASED FRAMEWORK FOR COMPARING fMRI ANALYSIS METHODS

Gholam-Ali Hossein-Zadeh,¹ Ali-Mohammad Golestani,¹ Hamid Soltanian-Zadeh^{1,2}

1Control and Intelligent Processing Center of Excellence, Electrical and Computer Engineering Department, Faculty of Engineering, University of Tehran, Tehran 14395-515, Iran

2Image Analysis Lab., Radiology Department, Henry Ford Health System, Detroit, MI 48202, USA

ABSTRACT

In this paper, a cluster-based framework is introduced for comparing analysis methods of functional magnetic resonance images (fMRI). In the proposed framework, fMRI data is replaced with a feature space and each method considered as a clustering method in the new space. As a result, different methods can be compared by means of a cluster validity measure. The feature space is computed using a non-parametric method (principal component analysis-PCA). Four subjects have been analyzed with three methods and the proposed cluster-based framework has evaluated performance of the methods. The results are identical to those of the modified receiver operating characteristics (ROC). This validates the proposed approach.

1. INTRODUCTION

Technical fMRI researches have mostly focused on proposing new analysis methods or development and enhancement of available algorithms. Limited work has also been done on comparing different methods. Lange, et al. [1] used receiver operating characteristics (ROC) curve for comparing analysis algorithms. Yiong, et al. [2] developed the ROC method and introduced Sensitivity and Specificity as two comparison parameters. The limitation of this method is that active voxels should be known *a priori*. Thus, this method is only applicable to simulated data.

Another non-parametric comparison method is known as NPAIRS, proposed recently by Strother et al [3]. They divide the data set into two sets (training and test) and calculate prediction accuracy and reproducibility using the two data sets. Comparison is done based on the two calculated parameters (accuracy and reproducibility) [4]. A disadvantage of this method is its excessive calculations. In addition, this method requires several scans and several subjects.

Test-Retest is a non-parametric comparison method [5]. In this method, P_A (probability that a really active voxel is identified active) and P_I (probability that a truly really inactive voxel is identified active) are estimated using maximum likelihood algorithm. A proper analysis algorithm should have large P_A and small P_I [5]. Although this method does not need any knowledge

about active voxels, it needs several data sets so implementation of the method is difficult and expensive.

In 2003, Nandy and Cordes [6] modified ROC method so that it could be used for real data. They showed that the curve of $P(Y)$ (probability of a voxel identified active) against $P(Y|F)$ (probability of an inactive voxel identified active) is proportional to the conventional ROC curve. So the new ROC curve can be used for comparing analysis methods without prior knowledge of really active voxels. However, since probability density of signal and noise is not determined, modified ROC curves can only be estimated base on some assumptions.

In general, some criteria such as uncertainty about really active voxels and functional variability by subject and time make comparison difficult. Consequently, non-parametric, data-driven methods are superior to other methods. In this paper, we introduce a new method for comparing fMRI data analysis algorithms. Analysis methods are considered as clustering algorithms that separate voxels into active and inactive clusters. Therefore, they are compared using a cluster validity measure. Since no assumption about signal and noise and other factors is made, this method is valid in different conditions. In addition, general structure of the algorithm is flexible and can easily be improved by changing cluster validity measure or other parameters of the algorithm.

2. METHODS

2.1. Proposed Approach

Each analysis method has specific assumptions and model and presents a statistical map that shows active voxels. Apart from the model and computations, each method can be considered as a clustering method that separates fMRI time series into active and inactive clusters.

The proposed method uses a cluster validity measure for comparing different analysis algorithms. Among the different methods, the one that generates best clusters will be considered as the best method. A feature space is used for measuring goodness of the clustering method. Details of the feature space are explained in next section. Fig. 1 shows block diagram

of the proposed method. Steps of the algorithm are as follows:

1. A feature space is made from fMRI data (see next section)
2. Statistical maps of different analysis methods are generated for specific false alarm rate.
3. Statistical map of each method is used to determine active and inactive clusters in the feature space.
4. A cluster validity measure is used to compute goodness of each method.

2.2. Feature Space

A proper feature space for evaluating performance of different methods should generate features that: 1) can discriminate between active and inactive voxels so that separate clusters are generated in this feature space by different analysis methods; 2) are completely data-driven because using a specific model or assumption not only apply constrains of the model used and the assumptions but also bias the results towards the method that uses the same model.

We apply the principal component analysis (PCA) that is a data-driven method to generate the new feature space. Fig. 2 shows block diagram of the method proposed for computing the feature space. Each brain voxel (or fMRI time series) is described in this feature space with a vector. This vector is described by the projections of the corresponding fMRI time series onto the basis vectors of the feature space.

The basis vectors consist of two groups; each generated using PCA. The first group represents activity and is generated by applying PCA to the time series of the voxels identified active by all of the analysis methods. The eigenvectors corresponding to the largest eigenvalues are considered as the basis vectors. The second group represents rest (inactivity) and is generated by applying PCA to the time series of the voxels identified by all of the methods inactive. Again, the eigenvectors corresponding to the largest eigenvalues are considered as the basis vectors. After finding the basis vectors of the feature space, each time series is projected onto the basis vectors and the feature vector is generated for the corresponding voxel.

2.3. Data

The fMRI data we used in our work is from a sensory-motor task, collected using a 1.5T scanner. Four subjects were imaged. The stimulus was controlled by a computer and consisted of 1.5sec visual stimulus. Subjects pressed a key with their right index finger at the stimulus onset. The visual stimulus was an 8 Hz flickering (black to white) checkerboard. Runs were structured so that for every eight image acquisition (21.44 sec) one-trial or two-trials with 5.36 sec inter-trial intervals were presented [7].

Several T2* weighted MR images were acquired using asymmetric spin echo pulse sequence. Each

volume image consisted of 16 slices and each slice had 64x64 pixels. 128 volume images were acquired. Anatomical images consisted of 128 sagittal slices with 256x256 resolutions. We used these images for active region localization in AFNI software.

3. EXPERIMENTAL RESULTS

We implemented and tested three algorithms: Correlation method; F-test method; and translation invariant wavelet-based method (for further information refer to references [8], [9], [10]). These three methods were applied on the functional images of each subject. Consequently, for each subject and for each specific false alarm rate (0.001, 0.005, 0.01, 0.05, 0.1) three activation maps were produced. Common active and inactive voxels among the three maps were identified and the proposed feature space computed. Active and inactive eigenvectors that describe 90% of the data variation were chosen as basis vectors. In the new feature space, centers of the active and inactive clusters were calculated.

Cluster validity measure we used is the ratio of distance between the two cluster centers to their average standard deviation (square root of the average of the two cluster variances). Fig. 3 shows the diagram of the cluster validity measure against the false alarm rate for one of the subjects. As a reference, modified ROC curve for the same subject is also shown. Diagrams of other three subjects are identical to this plot. Two plots of Fig. 3 are compatible: in both cases wavelet-based method is superior to the other two methods while F-test always gives the weakest result. For qualitative evaluation, active regions of the three methods at the 0.001 false alarm rate are shown in Fig. 4.

4. CONCLUSION

We developed a framework for evaluation and comparison of different fMRI analysis methods. In this framework, each analysis method is considered as a clustering algorithm and different methods are compared with a numerical measure for the cluster validity. The feature space used for the clustering is computed using a non-parametric method (PCA) so the results are not biased towards a specific model or assumption. Using the proposed framework, we compared three analysis methods. Results of this comparison were identical to the modified ROC results. The proposed comparison method is flexible and can be easily modified by changing the feature space method and the cluster validity measure used in it.

5. REFERENCES

- [1] N. Lange, P.A. Bandettini, J.R. Baker, B.R. Rosen, *A Comparison of Activation Detection Methods in Functional*

MRI, Proceeding of Third Annual Meeting of the Society of Magnetic Resonance, France, P 828, 1995.

[2] J. Xiong, J.H. Gao, J.L. Lancaster, P.T. Fox, *Assessment and Optimization of Functional MRI Analysis*, Human Brain Mapping, Vol. 4, pp 153-167, 1996.

[3] S.C. Strother, J. Anderson, L.K. Hansen, U. Kjems, R. Kustra, J. Sidtis, S. Frutiger, S. Muley, S. LaConte, D. Rottenberg, *The Quantitative Evaluation of Functional Neuroimaging Experiments: The NPAIRS Data Analysis Framework*, NeuroImage, Vol. 15, pp 747- 771, 2002.

[4] S. LaConte, J. Anderson, S. Muley, J. Ashe, S. Frutiger, K. Rehm, L. K. Hansen, E. Yacoub, X. Hu, D. Rottenberg, S. Strother, *The Evaluation of Preprocessing Choices in Single-Subject Bold fMRI Using NPAIRS Performance Metrics*, NeuroImage, Vol. 18, pp 10-27, 2003.

[5] C.R. Genovese, D.C. Noll, W.F. Eddy, *Estimating Test-Retest Reliability in Functional MR Imaging I: Statistical Methodology*, Magnetic Resonance in Medicine, Vol. 38, pp 497-507, 1997.

[6] R.R. Nandy, D. Cordes, *Novel ROC-Type Method for Testing the Efficiency of Multivariate Statistical Methods in fMRI*, Magnetic Resonance in Medicine Vol. 49, pp 1152-1162, 2003.

[7] R.L. Buckner, A.Z. Snyder, A.L. Sanders, M.E. Raichle, J.C. Morris, *Functional Brain Imaging of Young Nondemented and Demented Older Adults*, Journal of Cognitive Neuroscience, Vol. 12, pp 24-34, 2000.

[8] P.A. Bandettini, A. Jesmanowicz, E.C. Wong J.S. Hyde. *Processing Strategies for Time-Course Datasets in Functional MRI of the Human Brain*, Magnetic Resonance in Medicine, Vol. 30, pp 161-173, 1993.

[9] G.A. Hossein-Zadeh, B.A. Ardekani, H. Soltanian-Zadeh, *A Signal Subspace Approach for Modeling the Hemodynamic Response Function in fMRI*, Magnetic Resonance Imaging, Vol. 21, No. 8, pp 843-853, 2003.

[10] G.A. Hossein-Zadeh, H. Soltanian-Zadeh, B.A. Ardekani, *Multi-Resolution fMRI Activation Detection Using Translation Invariant Wavelet Transform and Statistical Analysis Based on Resampling*, IEEE Trans. Medical Imaging, Vol. 22, No. 3, pp 302-314, 2003.

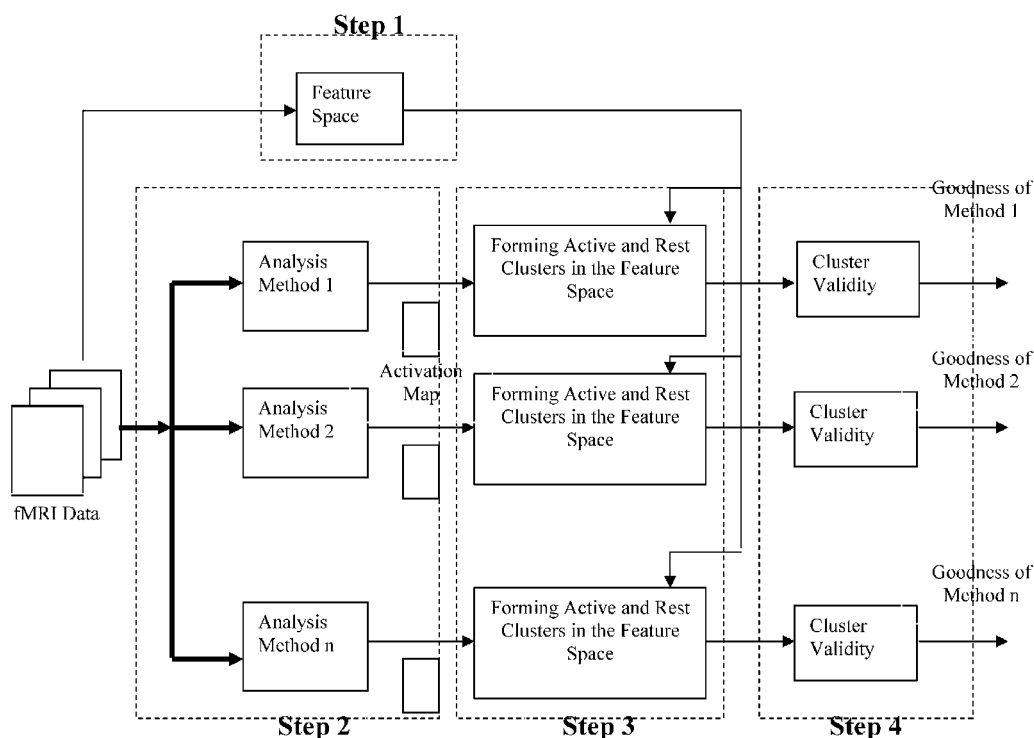

Fig. 1 . Block diagram of the proposed method for comparing fMRI analysis methods.

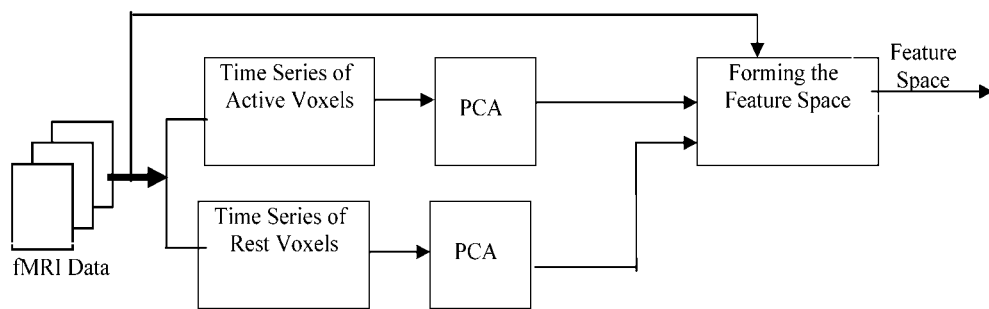

Fig. 2. Block diagram of the method proposed for computing the basis vectors of the new feature space.

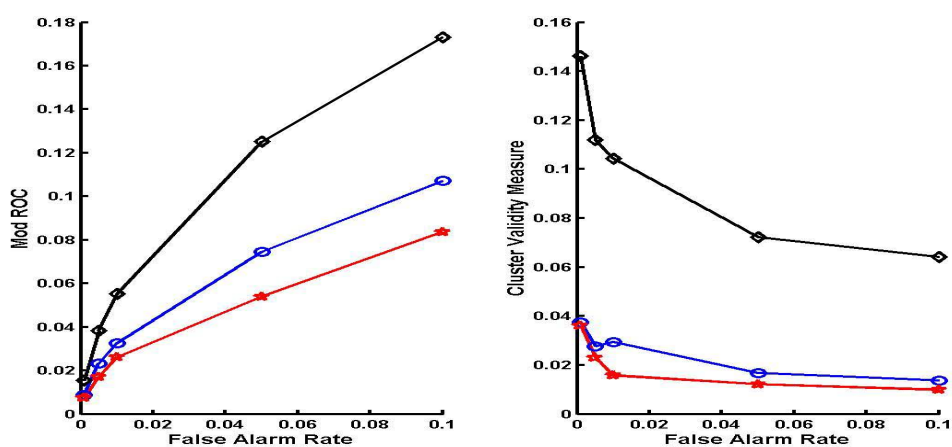

Fig. 3. Plots of modified ROC (left) and cluster validity measure (right) against false alarm rate for the three analysis methods (Circle: Correlation method, star: F-test, diamond: wavelet-based method).

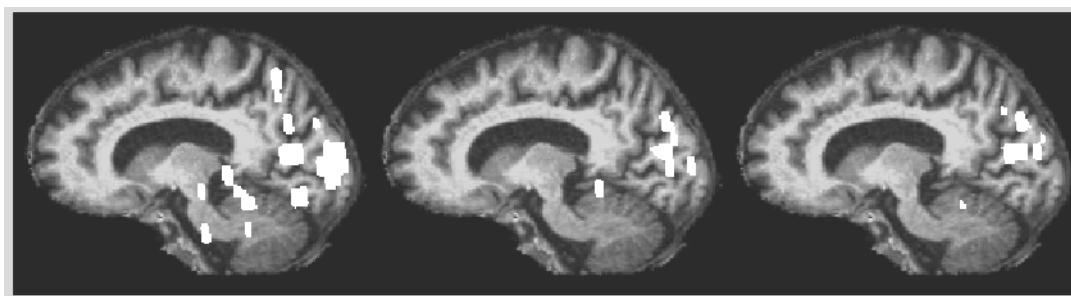

Fig. 4. Active regions for the three analysis methods (left: Wavelet-based method, middle: F-test, right: Correlation method).